

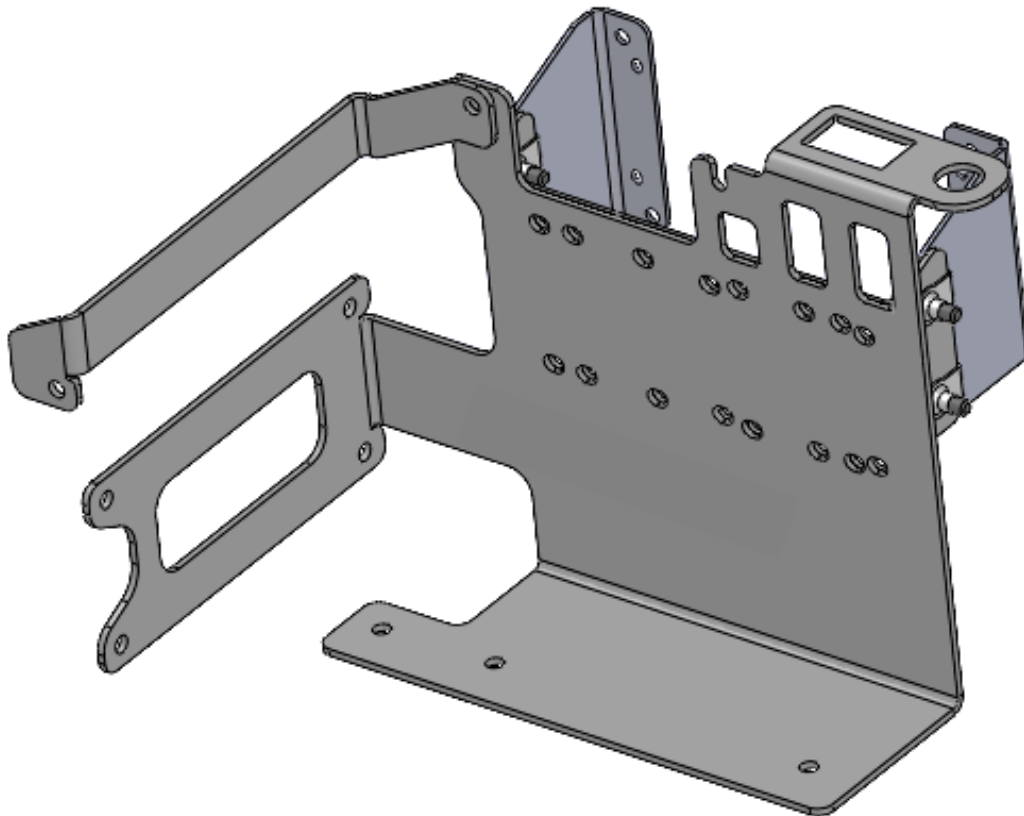

**COMPRESSOR BRACKET  
SUITS TOYOTA PRADO 250 2024ON**

***INSTALLATION GUIDE***

**0880001**



No liability is assumed for damages resulting in the use of the information contained herein.

ARB Air Locker Air Operated Locking Differentials, ARB Air Locker Air Activation System and Air Locker are trademarks of ARB Corporation Limited.

Other product names used herein are for identification purposes only and may be trademarks of their respective owners.

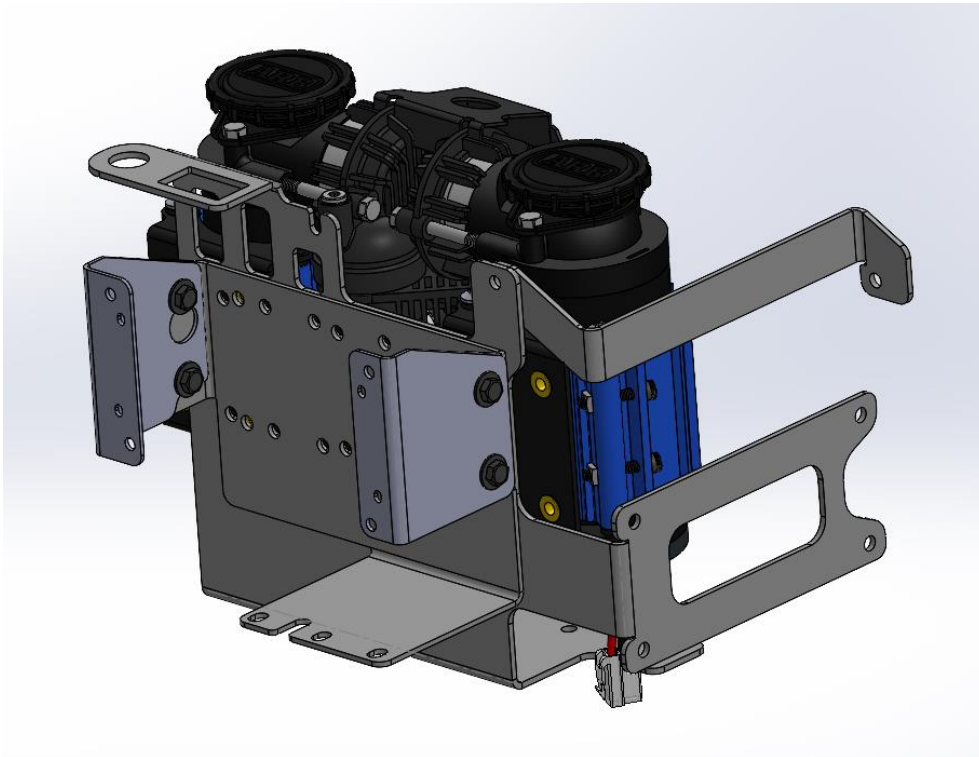

---

## **ARB 4x4 ACCESSORIES**

Corporate Head Office

42-44 Garden St  
Kilsyth, Victoria  
AUSTRALIA  
3137

Tel: +61 (3) 9761 6622

Australian enquiries  
North and South American enquiries  
Other international enquiries

[sales@arb.com.au](mailto:sales@arb.com.au)  
[sales@arbusa.com](mailto:sales@arbusa.com)  
[exports@arb.com.au](mailto:exports@arb.com.au)

---

**[www.arb.com.au](http://www.arb.com.au)**

# Table of Contents

## **1 Introduction**

1.1	Pre-Installation Preparation .....	4
1.2	Kit Description .....	4
1.3	Compatible Products.....	4
1.4	Kit Contents .....	5
1.5	Tool-Kit Recommendations .....	6
1.5.1	Tools.....	6
1.5.2	Supplies .....	6

## **2 Remove Vehicle Components**

2.1	Disconnect Vehicle Battery .....	7
2.2	Remove Washer Fluid Fill Tube .....	7
2.3	ECU Removal .....	8

## **3 Compressor Bracket Pre-Assembly**

3.1	Compressor Bracket Pre-Assembly .....	11
-----	---------------------------------------	----

## **4 Installation**

4.1	Brushless Compressor Installation .....	13
4.2	Brushed Compressor Installation .....	18
4.3	Manifold Installation (Optional) .....	25
4.4	Finalise Installation .....	29
4.5	Post-Installation .....	31

## IMPORTANT:

To ensure the highest level of planning and reliability goes into this installation, please read this guide in its entirety before attempting any modifications to the vehicle.

### 1.1 Pre-Installation Preparation

Your ARB Air Compressor Bracket kit comes with comprehensive step by step instructions needed for installation. However, it is recommended that your ARB Air Compressor Bracket installation be performed by a qualified professional. ARB has trained distributors worldwide to ensure a class leading installation process that won't let you down.

To ensure a smooth and efficient installation, please verify that the Air Compressor Bracket kit is compatible with your specific application and includes all required components listed in Section 1.4. Additionally, ensure that you have acquired the necessary tools, parts, and materials for the installation process as outlined in Section 1.5.

For comprehensive information on operating, servicing, and troubleshooting your ARB Compressor and/or Air Locker(s), please consult your ARB Compressor and Air Locker Operating & Service Manuals.

**HINT:** Place a ✓ mark inside each of the  symbols as you complete each step. It is very important NOT to miss any of the steps!

### 1.2 Kit Description

The Prado Compressor Bracket allows you to install an ARB Single or Twin Compressor (Including ARB Brushless Compressors)

### 1.3 Compatible Products

- CKBLA – Brushless Single On-Board Compressor
- CKBLTA – Brushless Twin On-Board Compressor
- CKMTA – Brushed Single On-Board Compressor
- CKMA – Brushed Twin On-Board Compressor
- CKSA - Compact On-board (Single) Compressor
- ARB Air Lockers (including Solenoid Kits)
- 171319 Air Filter Relocation Kit - 2x kits required when used with the CKMTA
- 171503 Compressor Manifold Kit

# 1 Introduction

## 1.4 Kit Contents

Item	Part No.	Description	Qty.	Notes
1	37501082	ECU MOUNT BRACKET LH	1	
2	37501083	ECU MOUNT BRACKET RH	1	
3	37501081	COMPRESSOR BRACKET A	1	
4	4681970	COMPRESSOR MOUNTING BRACE	1	
5	37501080	COMPRESSOR BRACKET B	1	
6	6178692	FIT KIT FOR COMPRESSOR BRACKET	1	
7	37501079	MANIFOLD MOUNTING BRACKET (US VEHICLES)	1	SEE NOTE 1
8	37501078	MANIFOLD MOUNTING BRACKET (AU VEHICLES)	1	SEE NOTE 1
9	180226	COMPRESSOR SWITCH BLANKING PLATE	1	SEE NOTE 1
10	171403	HOSE PUSH COUPLING US STD (F) JIC-4	1	SEE NOTE 1
11	6151475	U-NUT M6x1.0	4	SEE NOTE 1
*	6151020	BOLT HEX HEAD M8x1.25x16	2	SEE NOTE 1
*	6151560	BOLT HEX HEAD M6x1.0x16	18	SEE NOTE 1
*	4584327	WASHER FLAT M6x16x1.2	4	SEE NOTE 1
*	4584329	WASHER FLAT M6x12.2x1.2	28	SEE NOTE 1
*	6151223	NUT HEX NYLON LOCKING M6x1.0	14	SEE NOTE 1
*	6151213	BOLT HEX HEAD M6x1.0x20	4	SEE NOTE 1
*	4584336	WASHER FLAT M8x17x1.6	2	SEE NOTE 1
*	0740203	HOSE REINFORCED 1 MTR	1	SEE NOTE 1
*	180305	CABLE TIE PACK 3.5mm x 18mm	1	SEE NOTE 1
*	37800496	FITTING INSTRUCTIONS	1	SEE NOTE 1

\* Not illustrated in exploded view

### NOTES

- Included in Fit Kit 6178692

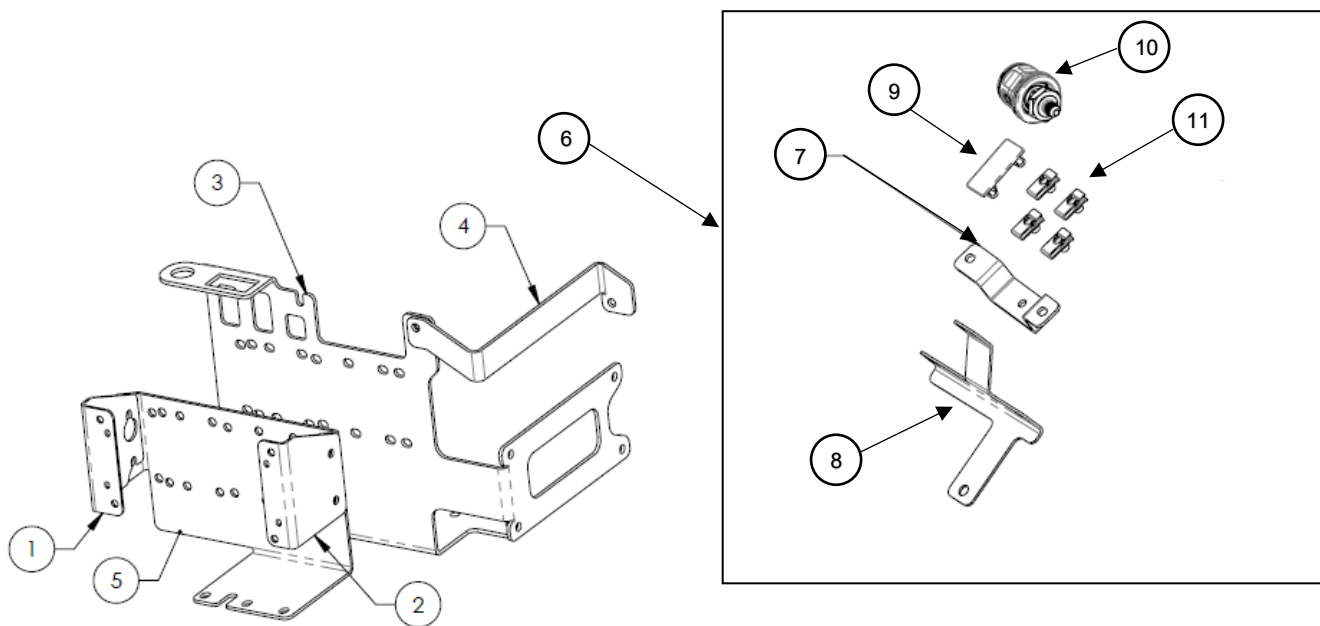

Figure 1. Exploded view & Fit Kit contents

# 1 Introduction

## 1.5 Tool-Kit Recommendations

Below is a list of tools and supplies recommended to complete this installation.

### 1.5.1 Tools

- Standard automotive sizes (metric and/or imperial) of sockets, spanners, Allen keys, power drill/driver, No.2 Phillips and T30 Torx bits, Torque Wrench 5-20 Nm range
- Socket extension bar and articulated extension bar
- Razor knife to cut rubber hose
- Leak test gauge (i.e., ARB# ALTG01)
- Multimeter
- Soldering iron

### 1.5.2 Supplies

- Thread lubricant/sealant compound for pressure fittings (e.g., LOCTITE #567 Teflon paste or plumbing supply Teflon tape)
- Soapy water mixture to test for air leaks
- Electrical tape/heat shrink
- Solder and/or automotive crimp fittings

**NOTE:** Sealant is not required for JIC fittings or o-ring seals.



Figure 2. No sealant is required on JIC fittings or parallel threads

## 2 Remove Vehicle Components

### 2.1 Disconnect Vehicle Battery

- Disconnect vehicle negative battery terminal and wrap the clamp to avoid accidental contact during installation. Wait 10 minutes until proceeding to the next step.



Figure 3. Negative Battery terminal disconnected and wrapped with a rag

### 2.2 Remove Washer Fluid Fill Tube

- Carefully unclip the washer fluid fill tube from the radiator mount crossmember and gently pull up until the tube comes out of the rubber grommet in the washer bottle. Cover the hole in the top of the washer bottle to avoid debris entering the bottle.



Figure 4. Remove washer fluid fill tube

## 2 Remove Vehicle Components

### 2.3 ECU Removal

- Lift the locking levers on the three large ECU connectors and the single connector on the medium ECU and disconnect them in the number order shown below.

**NOTE:** Do not damage the fragile pins on the ECU.

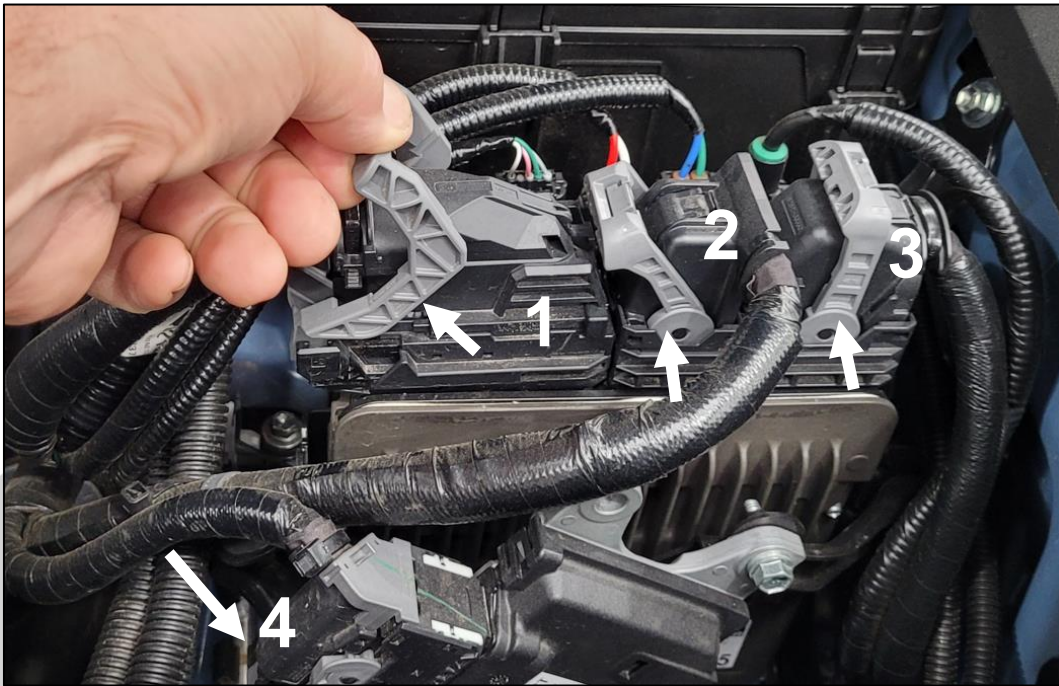

Figure 5. Remove the three large ECU connectors (1, 2, 3) and single connector on the medium ECU (4)

- Remove the four locking connectors from the small ECU.

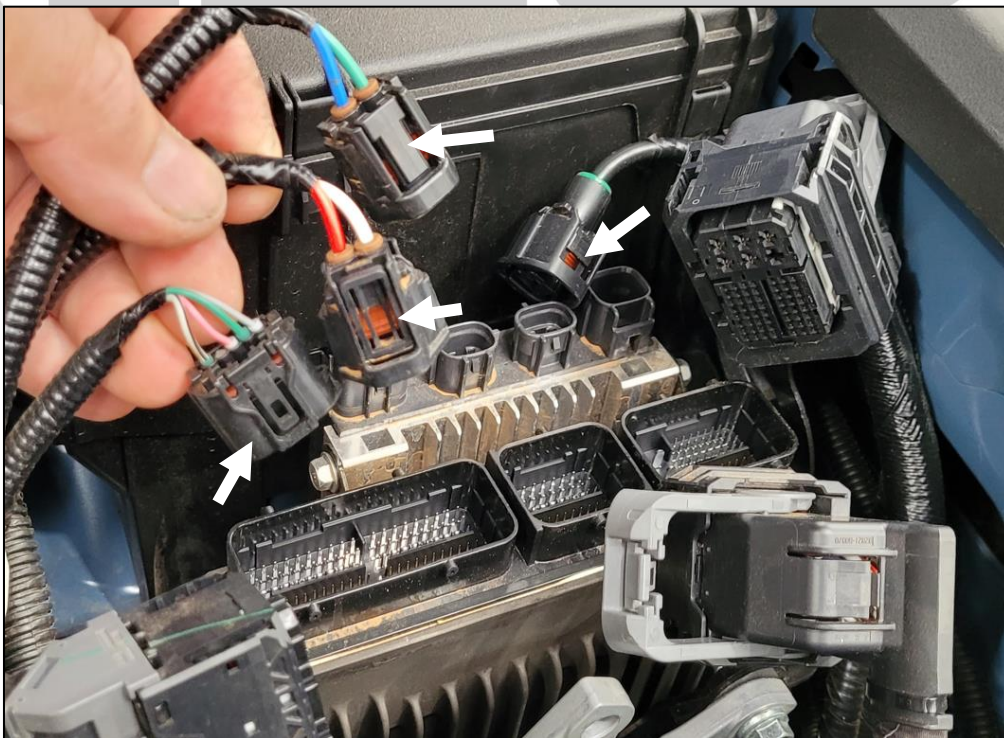

Figure 6. Locking tabs on the smaller connectors

## 2 Remove Vehicle Components

- Cut the tape on the ECU harness as shown below.



Figure 7. Cut tape to allow harness separation

- Use a 10 mm socket to remove the four hex fasteners holding the Toyota ECU bracket. Retain the fasteners.

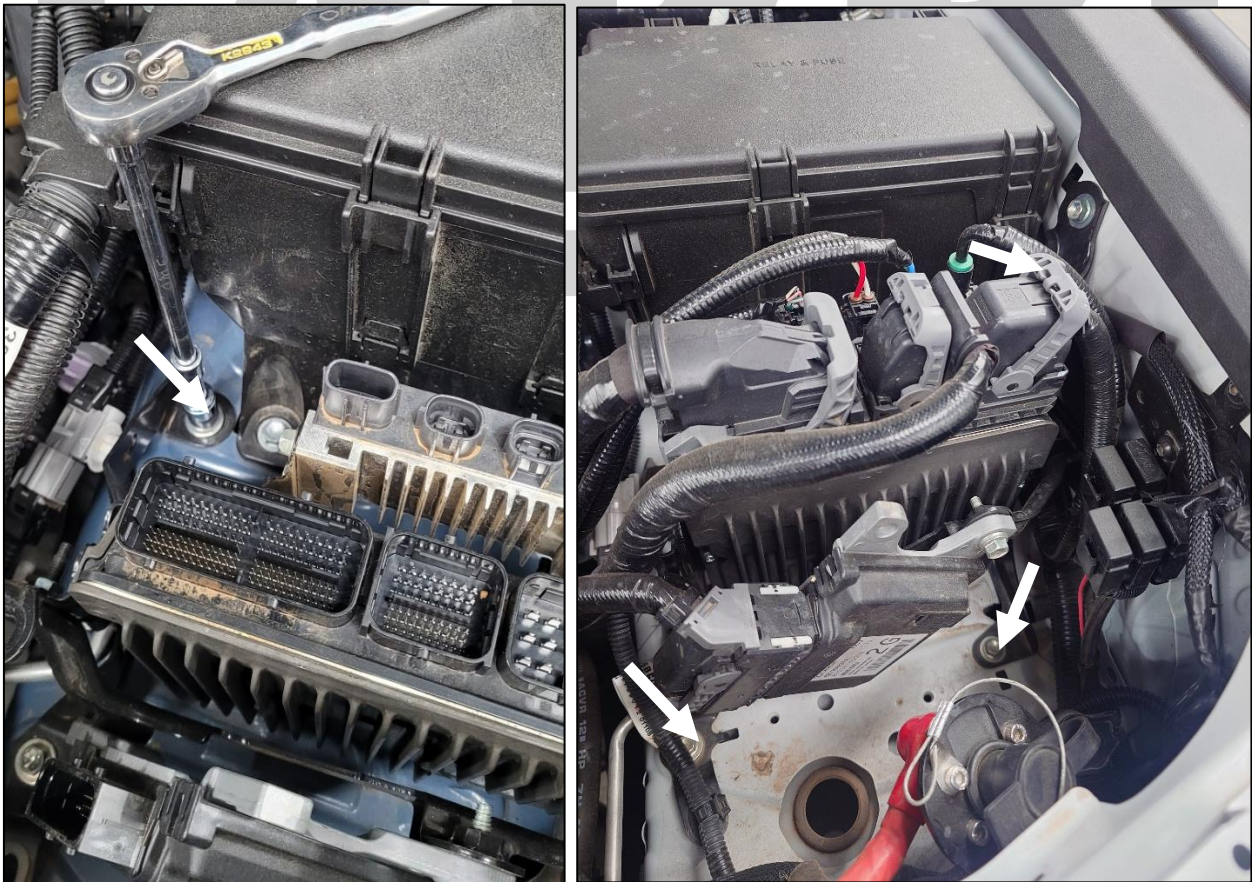

Figure 8. ECU bracket bolt location (Left), ECU bracket bolt location (Right)

## 2 Remove Vehicle Components

- Remove the ECUs from their bracket and retain the fasteners.



Figure 9. Fastener locations for medium ECU

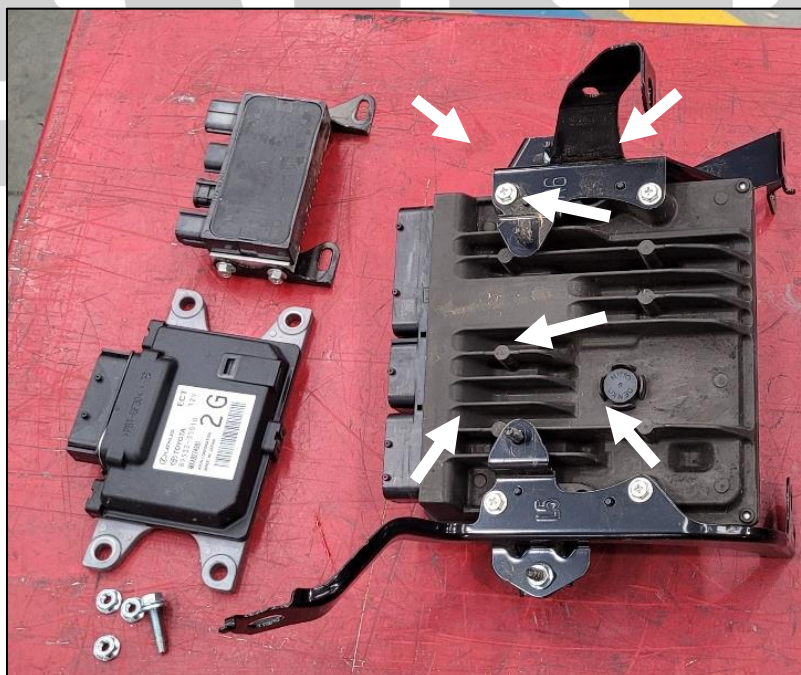

Figure 10. Fastener location for large ECU (Outer) and small ECU (Inner)

## 3 Compressor Bracket Pre-Assembly

### 3.1 Compressor Bracket Pre-Assembly

- Attach ECU mount brackets to the large ECU using the original fasteners. Take note of the orientation as pictured below.



Figure 11. Correct orientation of ECU brackets

- Prepare the compressor bracket B by adding four U-nuts as shown below.

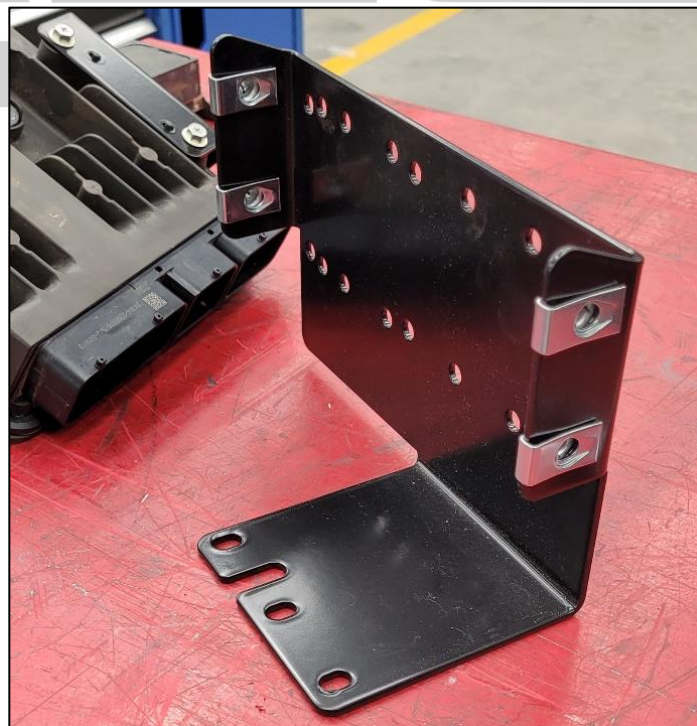

Figure 12. Correct U-nut orientation

### 3 Compressor Bracket Pre-Assembly

- Attach the medium ECU to the compressor bracket using ARB supplied M6x16 fasteners and flange nuts.

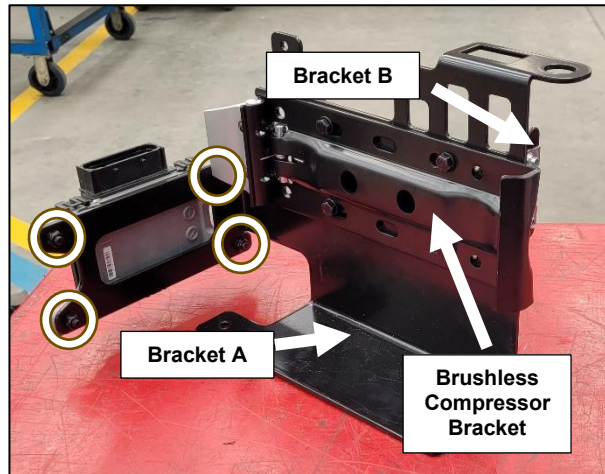

Figure 13. Medium ECU mounting position

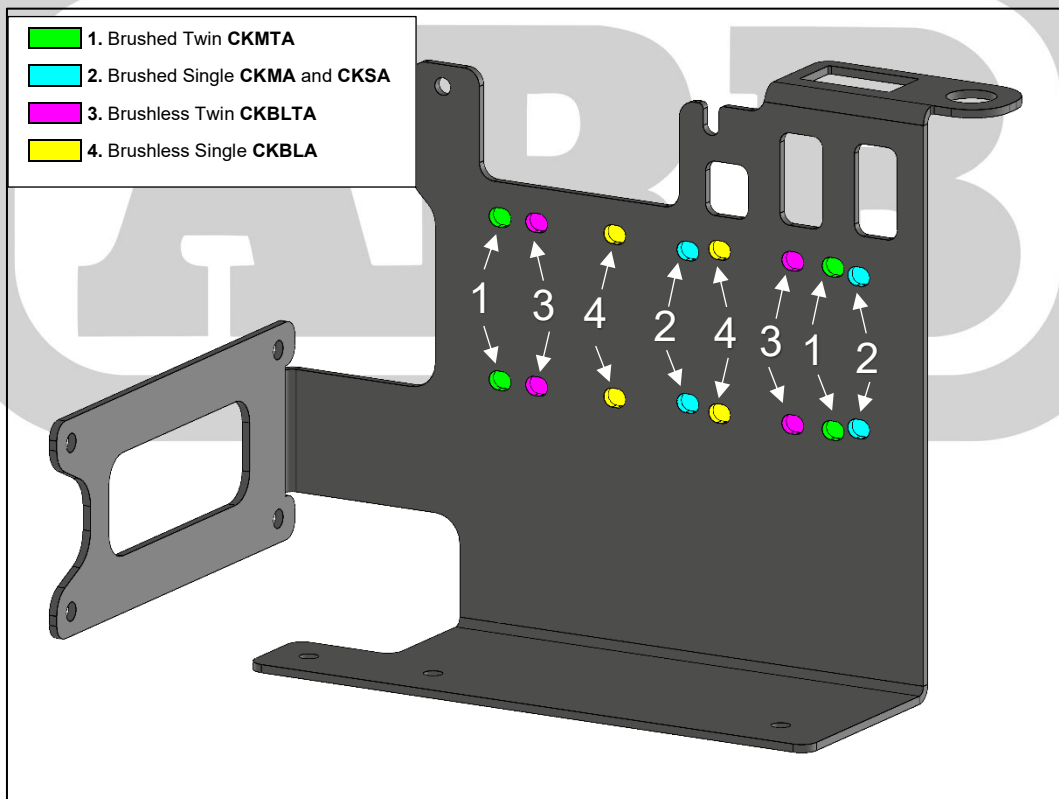

Figure 14. Mounting holes for different compressor models

## 4 Installation

### 4.1 Brushless Compressor Installation

- Line up the compressor mounting holes on compressor brackets 'A' and 'B'.
- Fasten the compressor mounting bracket to the compressor bracket using the holes pictured in Figure 14 above. This will also clamp the 'A' and 'B' brackets together
- Remove the two forward relay/fuse box mounting bolts.

**HINT:** Loosening the rear mounting bolts on the relay/fuse box will ease installation.



Figure 15.

Remove bolts

- Slide the bracket A and B assembly into position.
- Slide a M6 washer (A) under the outboard relay/fuse box leg before securing it with the original fastener.

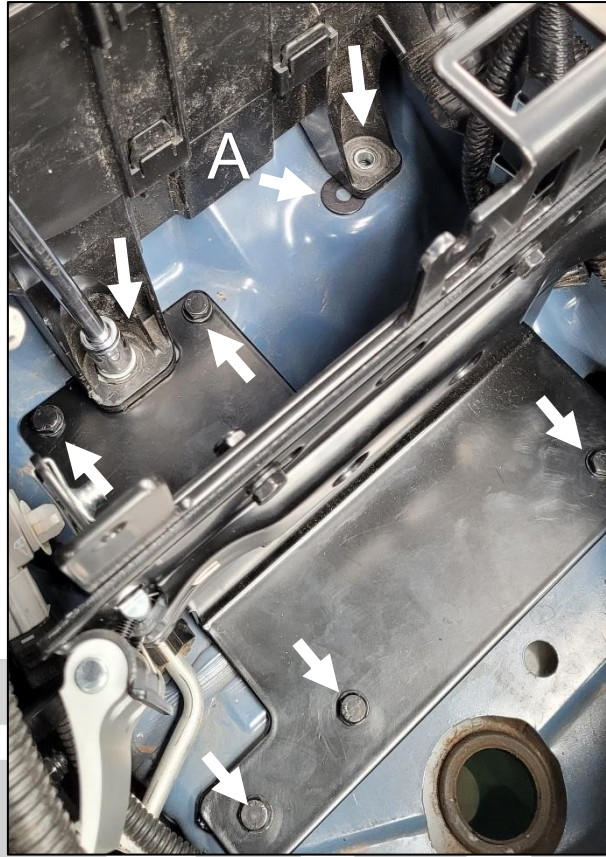

Figure 16. Fastener locations and added washer

- Use five M6 x 16 fasteners supplied in the fit kit as well as the original relay/fuse box fasteners to secure the assembly as shown above in Figure 16.

**NOTE:** For the US model, if the optional manifold kit (PN 171503) has been optioned, will need to be installed at this step. See section 4.3 for mounting position.

- Add M6 x 16 bolts and washers to the two U-nuts in the direction indicated in Figure 17 to simplify installation.

## 4 Installation

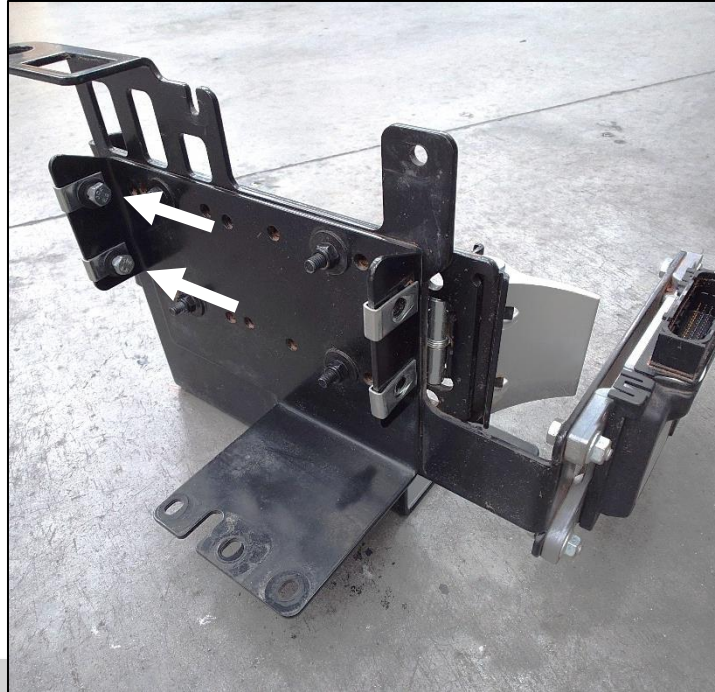

Figure 17. Add fasteners

- Slide the RH side of the ECU assembly over the previously added fasteners in the U-nuts (Figure 18) and add two M6 x 16 bolts and washers to the LH side of the ECU bracket as shown in Figure 19.

**HINT:** Only do these four bolts finger tight to check appropriate clearance between the ECU plugs and relay/fuse box



Figure 18. Ensure that the bracket is fully engaged with the fasteners



Figure 19. ECU LH side bracket and fasteners

- Ensure there is sufficient clearance between the ECU plugs and the relay/fuse box.

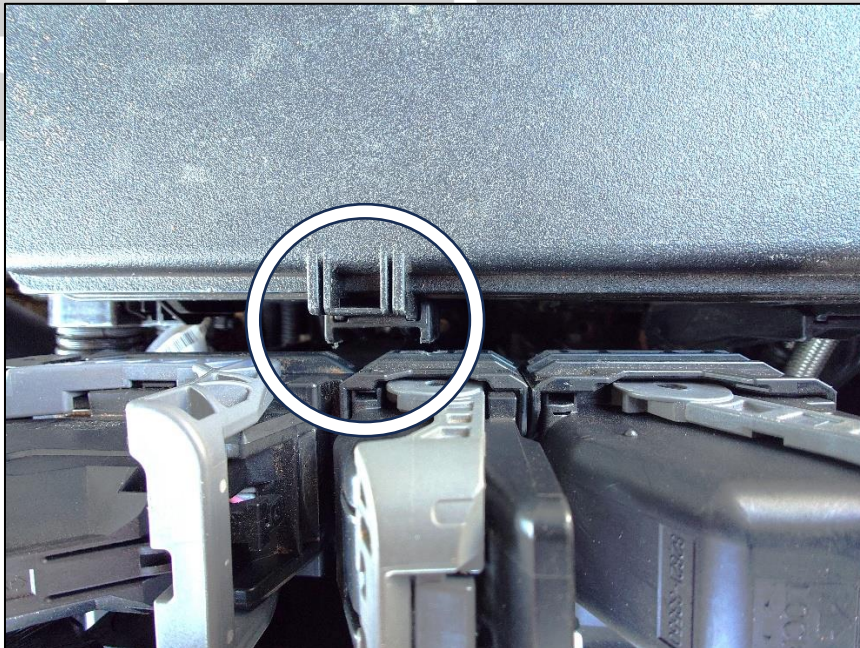

Figure 20. Gap between ECU and relay/fuse box

## 4 Installation

- Once there is sufficient clearance between the ECU plugs and relay/fuse box, tighten all four bolts to 9 Nm [7 lb.Ft].

**HINT:** You may need to hold the ECU forward in place when tightening the bolts to ensure that the clearance remains sufficient.

- Ensure that the wiring next to the medium ECU is tidy.
- Add a M6 x 16 bolt, washer and nut to the RH bracket of the small ECU and slot it in between the compressor bracket and the large ECU and into the slot shown below.



Figure 21. Slot for fastener

- Secure the LH bracket on the small ECU with the mounting brace as shown below using M6 x 16 fasteners.



Figure 22. Mounting brace fasteners

## 4 Installation

- Tighten both sets of fasteners to 9 Nm [7 lb.Ft].
- Plug all four connectors back into the small ECU.
- Plug all three connectors back into the large ECU and fasten the latches.
- Plug in the medium ECU and fasten the latch.

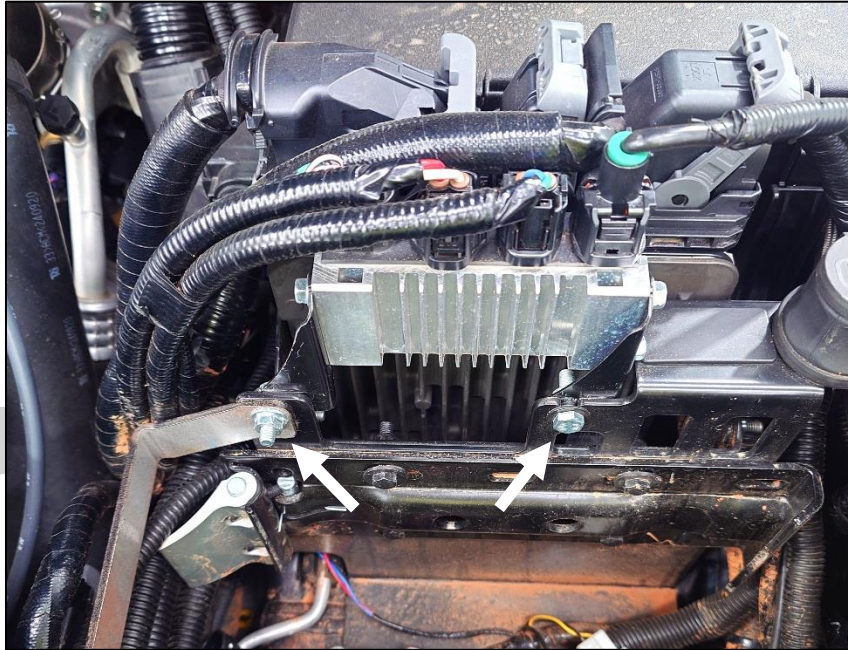

Figure 23. Small ECU in position

### 4.2 Brushed Compressor Installation

- Ensure the medium ECU is installed on bracket 'A' as shown in Figure 13 above.
- Mount the push fitting and compressor switch blanking plate (or compressor switch) to bracket 'A'
- Remove the two forward relay/fuse box mounting bolts.

**HINT:** Loosening the rear mounting bolts on the relay/fuse box will ease installation.

## 4 Installation



Figure 24. Remove bolts

- Slide a M6 washer (A) under the outboard relay/fuse box leg.

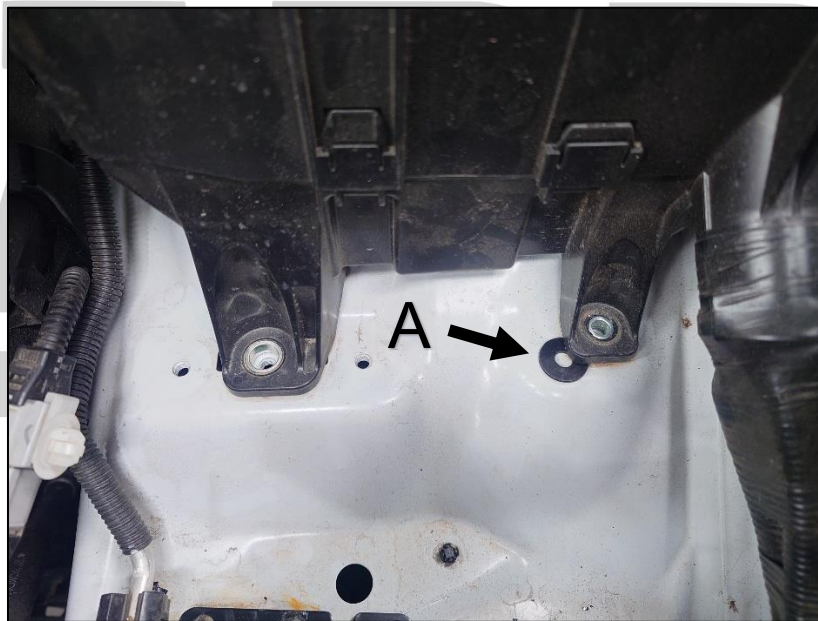

Figure 25. Washer 'A' under relay/ fuse box mount

- Slide the bracket B into position and loosely fit the two original bolts on the relay/fuse box and two M6 x 16 bolts and washers as supplied in the kit.

**NOTE:** Do not tighten yet.

**NOTE:** For the US model, if the optional manifold kit (PN 171503) has been optioned, and will need to be installed at this step. See section 4.3 for mounting position.

## 4 Installation



Figure 26. Fastener locations

- Fit bracket 'A' into position using the original bolts from the Toyota ECU bracket and tighten to 9 Nm [7 lb.Ft].

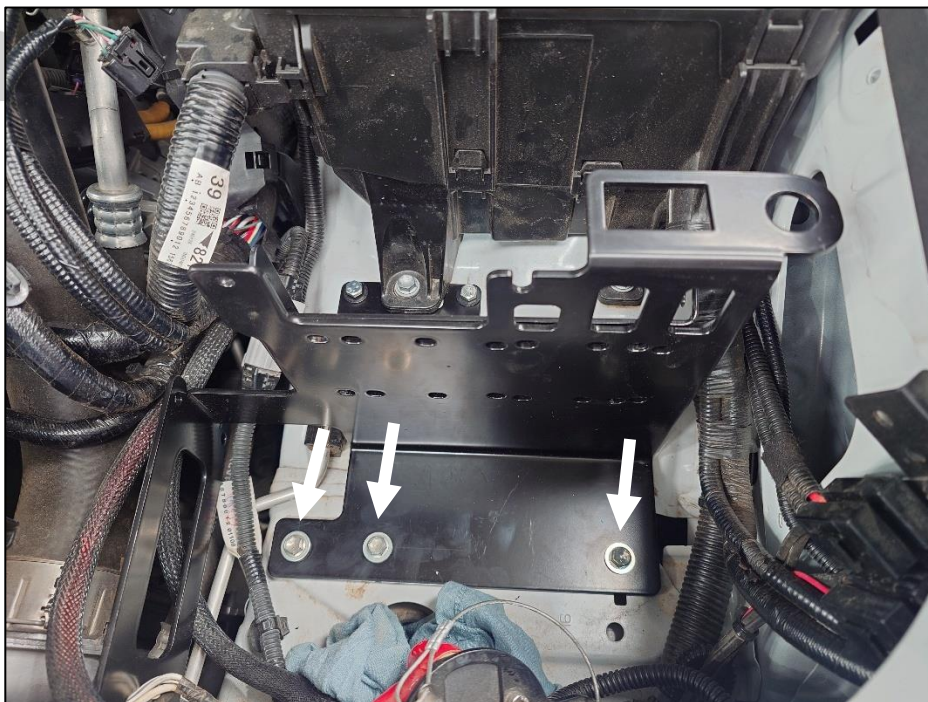

Figure 27. Bracket 'A' mounting position

## 4 Installation

- Hold compressor in place and line up holes in bracket 'A' and 'B' as well as the compressor and fit the bolts supplied with the compressor as shown in Figure 28 below.

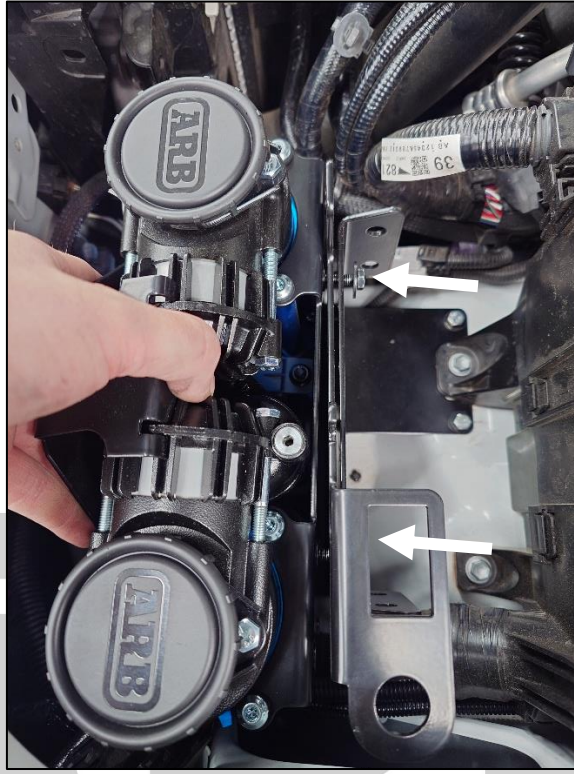

Figure 28. Hold brushed compressor in place

- Tighten the four compressor mounting bolts, the two mounting bracket bolts and the two relay/fuse box bolts to 9 Nm [7 lb.Ft].

**NOTE:** If the two relay/fuse box bolts on the back were loosened to ease installation, tighten them before proceeding

- Add M6 x 16 bolts and washers to the two U-nuts in the direction indicated in Figure 29 to simplify installation.

## 4 Installation

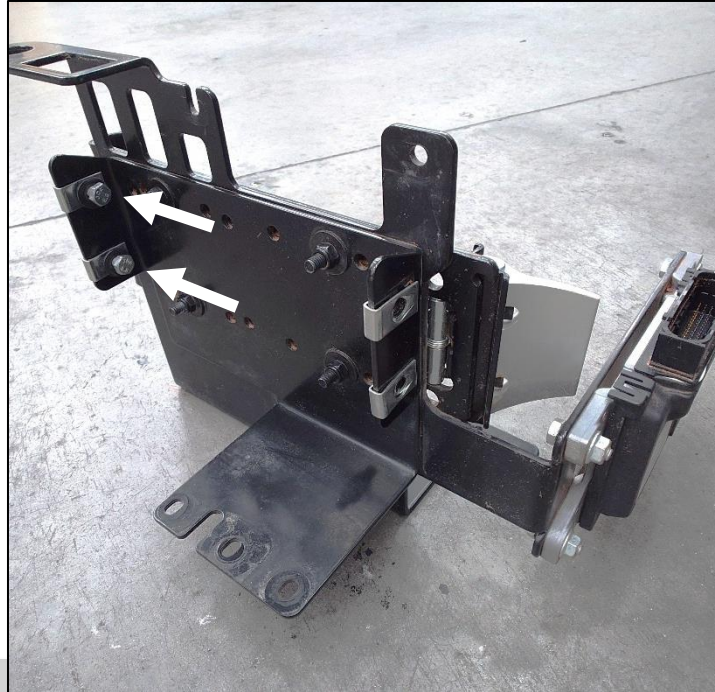

Figure 29. Add fasteners

- Slide the RH side of the ECU assembly over the previously added fasteners in the U-nuts (Figure 30) and add two M6 x 16 bolts and washers to the LH side of the ECU bracket as shown in Figure 31.

**HINT:** Only do these four bolts finger tight to check appropriate clearance between the ECU plugs and relay/fuse box



Figure 30. Ensure that the bracket is fully engaged with the fasteners



Figure 31. ECU LH side bracket and fasteners

Ensure there is sufficient clearance between the ECU plugs and the relay/fuse box.

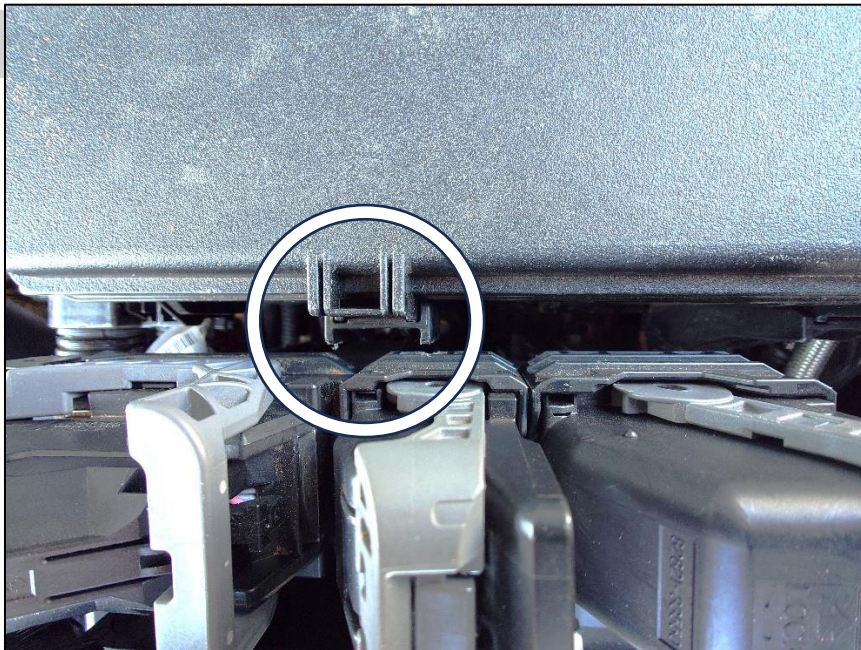

Figure 32. Gap between ECU and relay/fuse box

## 4 Installation

- Once there is sufficient clearance between the ECU plugs and relay/fuse box, tighten all four bolts to 9 Nm [7 lb.Ft].

**HINT:** You may need to hold the ECU forward in place when tightening the bolts to ensure that the clearance remains sufficient.

- Ensure that the wiring next to the medium ECU is tidy.
- Add a M6 x 16 bolt and nut NO washer to the RH bracket of the small ECU and slot it in between the compressor bracket and the large ECU and into the slot shown below.

**NOTE:** The bolt will not fit if a washer is used under the head of the bolt due to the position of the compressor housing

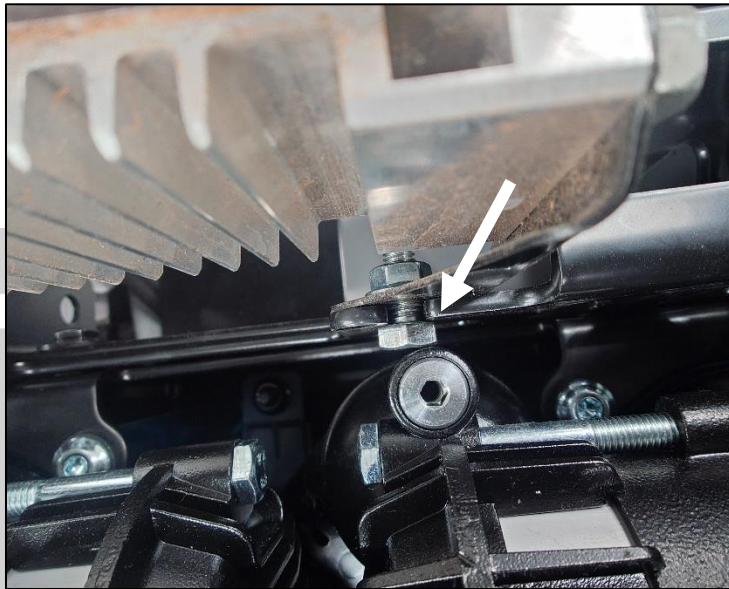

Figure 33. Slot for fastener with no washer

- Secure the LH bracket on the small ECU with the mounting brace as shown below using M6 x 16 fasteners.



Figure 34. Mounting brace fasteners

- Tighten both sets of fasteners to 9 Nm [7 lb.Ft].

## 4 Installation

- Plug all four connectors back into the small ECU.
- Plug all three connectors back into the large ECU and fasten the latches.
- Plug in the medium ECU and fasten the latch.

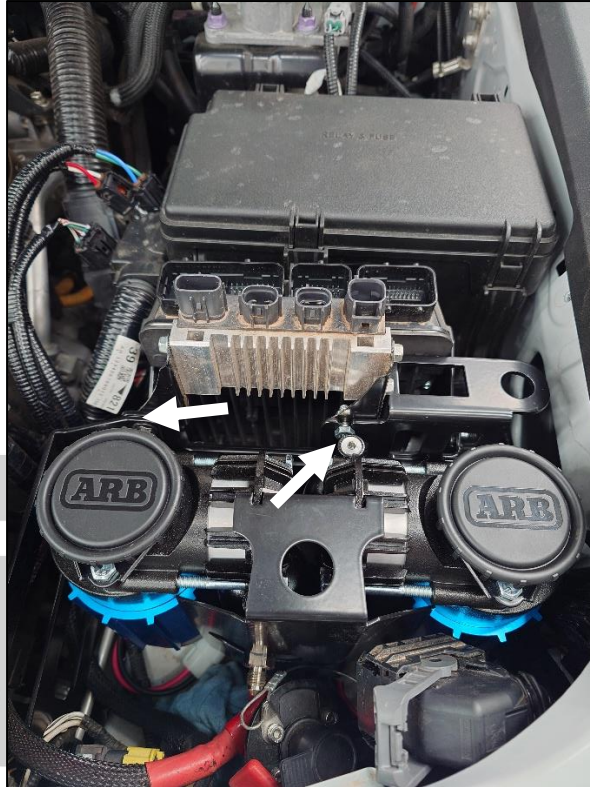

Figure 35. Small ECU Mounting

### 4.3 Manifold Installation (Optional)

**NOTE:** ARB Compressors are not supplied with the manifold kit (PN 171503). Accessories that mount onto the manifold are available separately. If no manifold is to be installed, proceed to Section 4.4

- Attach the manifold to the manifold bracket using M6 x 16 fasteners.



Figure 36. Manifold attachment and recommended orientation (AU Model)

## 4 Installation

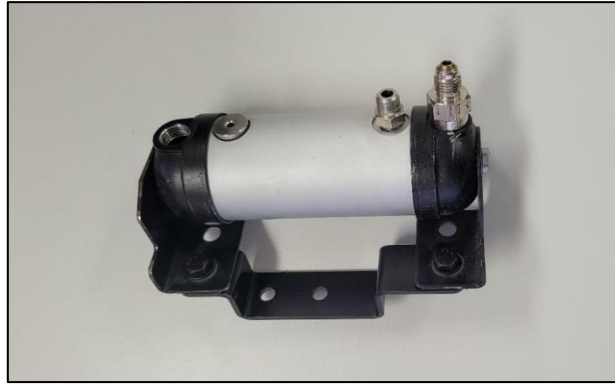

Figure 37. Manifold attachment and recommended orientation (US Model)

- Rotate the manifold end caps and barrel to your preferred orientation by loosening the end cap bolts.
- Attach the manifold assembly to the vehicle with two included M8x16 fasteners.

**NOTE:** For AU model vehicles, manifold assembly mounting position is behind the relay/fuse box as shown in Figure 38 and Figure 39 below.

**NOTE:** For the US model, the manifold assembly is mounted in front of the relay/fuse box as shown in Figure 40.

**NOTE:** Manifold shown below is fitted with optional accessories available through your local ARB Dealer

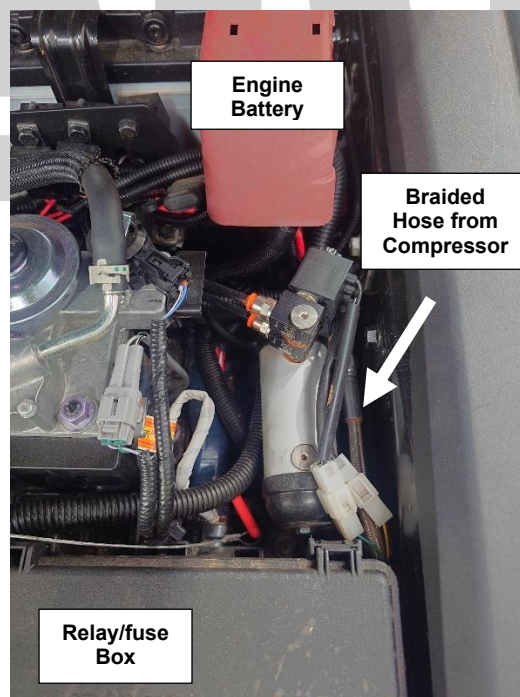

Figure 38. Manifold location (AU model)

## 4 Installation

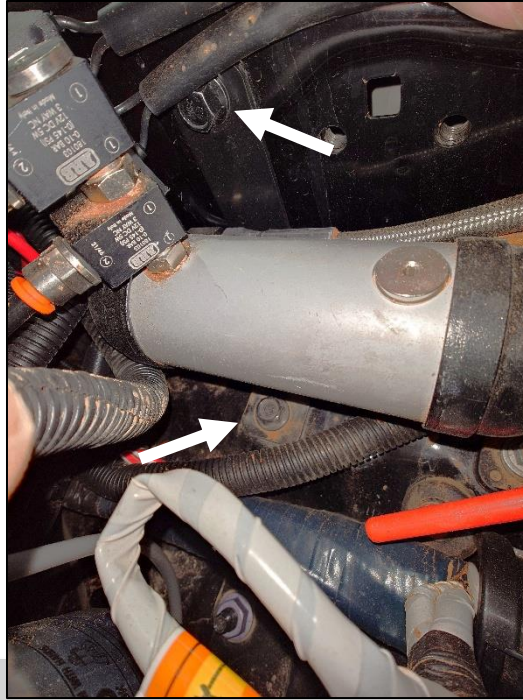

Figure 39. Two manifold fastener locations (AU model)



Figure 40. Two manifold fastener locations (US Model)

- Attach accessories to the manifold as desired.

**NOTE:** Sealant is not required for JIC fittings. See Figure 2

- Pass the braided air hose supplied in the bracket kit around the relay/fuse box with one end at the manifold as pictured above in Figure 38 and below in Figure 41. Secure the braided hose in such a way to avoid contact with the harness or other wiring.



**Figure 41. Compressor end of the braided hose**



## 4 Installation

### 4.4 Finalise Installation

- Depending on your desired setup, Install the compressor switch or compressor switch blanking plate and push coupling onto the top of the compressor bracket.
- For no manifold fitment. Fit the supplied braided hose to the push coupling fitting.
  - If a manifold is installed, fit the longer hose supplied with the bracket kit to the manifold end cap fitting furthest away from the compressor as shown below in Figure 42.
  - Fit the short hose supplied with the manifold kit to the remaining fitting on the other manifold end cap and the push coupling fitting.



Figure 42. Compressor to manifold hose connection

- Wire your compressor according to its installation instructions.



Figure 43. Recommended mounting location for compressor fuses



Figure 44. Preferred body grounding point

- Connect the braided hose to your compressor outlet port.

**NOTE:** Sealant is not required for JIC fittings. See Figure 2

- Slide your compressor into position and tighten the mounting clamps according to instructions provided with the compressor.

## 4 Installation

- Reinstall the wiper fluid fill tube.



Figure 45. Final installation

- Unwrap the battery terminal clamp and reconnect the vehicle battery.

### 4.5 Post-Installation

Test your compressor installation according to its installation guide.

The Troubleshooting sections in the compressor guides are still applicable to this bracket installation.