

DECKED

INSTALLATION INSTRUCTIONS*

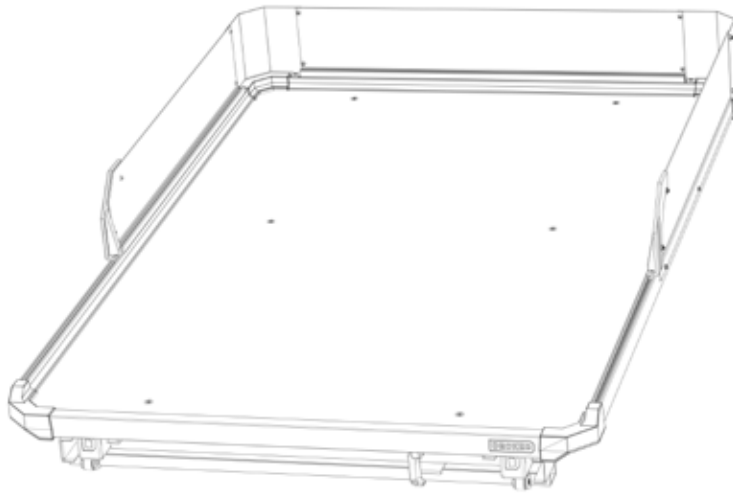

CARGOGLIDE XL CG1000XL/CG1500XL/ CG2200XL TRUCK BED INSTALL

***MAY NOT BE INSTALLED ONTO A
DECKED DRAWER SYSTEM***

NOT RECOMMENDED FOR COMPOSITE BEDS

****SEE SPECIAL INSTRUCTIONS FOR ELECTRIC VEHICLES
AND VEHICLES WITH GENERATORS****

***Trust us on this one; don't go commando and attempt your install without reading.
You'll just cuss a bunch and create even more chaos in your truck bed.**

TOOLS REQUIRED

- drill
- 5/16" and 1/2" drill bits
- tape measure
- crescent wrench
- knife
- 1/2" socket
- ratchet or impact driver

INSTALL VIDEO

High tech link to video here or you can visit decked.com/installvideo



CONTENTS

- plus nut tool (assembled on 2.5" bolt with washer and plus nut)
- mounting hardware: plus nuts, 1.5" bolts, washers
- tie down eye bolts: eye bolts, nylon washers, weld nuts
- PRIMER

HEY! TORQUE BOY

READ BEFORE YOU INSTALL

Welcome to DECKED! In a world of crappy instructions, bad advice, and questionable sources of truth, we are here to make sure that your install goes as smoothly as possible, saving you headaches and heartburn. That said, your part is to read the darned instructions!

Warning: It is the responsibility of the installer to ensure the DECKED CG1000XL/CG1500XL/CG2200XL unit is securely fastened to a base which will provide safe and reliable operation.

DO NOT INSTALL ON DROP-IN PLASTIC BEDLINERS, RUBBER MATS OR COMPOSITE BEDS.

The many variations in application and placement of a sliding platform present specific issues to consider for safety and utility. The following recommendations are intended to be general in nature and provide important safety information for the installer to consider during installation.

DECKED DRAWER SYSTEM COMPATIBILITY:

CGXL's are not recommended for installation on top of a DECKED drawer system.

****SEE SPECIAL INSTRUCTIONS FOR ELECTRIC VEHICLES
AND VEHICLES WITH GENERATORS****

USAGE

All DECKED CargoGlide units are designed for use in stationary and level conditions only. When installed in a vehicle, the DECKED CargoGlide unit must be closed and latched securely prior to and during any vehicle movement. The vehicle must be parked in a level position prior to unlocking and extending a DECKED CargoGlide unit; otherwise, the weight of your cargo could be difficult or dangerous to move. Control loads by opening and closing slowly. Heavy, uncontrolled loads may cause bodily injury or damage your DECKED CargoGlide latch or safety stop systems. Regular inspection is recommended.

FORCES

The DECKED CargoGlide unit must be securely fastened to a base floor or other structure to prevent movement. A tipping force is applied to the unit when it is extended, which is countered by the attachments at the front (cabside) and middle of the unit. Furthermore, vehicle acceleration, cornering and braking will result in additional forces affecting your cargo and the DECKED CargoGlide unit. Impacts due to dropping a load will result in temporary higher forces impacting the fasteners and should be avoided.

SPACERS, DROP LINKS AND DECKED SHOULDER BOLTS

Many vehicle compartments have a lip on the bottom of the bed, or angled tailgates and other obstructions above the floor level. Some truck beds may require a spacer kit to clear the obstruction or tailgate angle during extension of the sliding deck. The spacers must be placed under all of the DECKED CargoGlide areas that normally contact the floor to provide necessary support.

Spacer kits are available for all models; these are sold separately.

Tailgate cable Drop Links and DECKED shoulder bolts will work for some models - call us with any questions at 208-806-0251.

To assure the tailgate never interferes with the DECKED CargoGlide system, there should be at minimum of 1" - 2" of vertical clearance, with no load, between the tailgate and the lowest extended point of the DECKED CargoGlide. CG1000XL, CG1500XL and CG2200XL models have slight inclines to aid in clearing the open tailgate. Test the fit and function to determine if spacers are needed BEFORE drilling into your bed. General rule: the highest point on the tailgate must be less than 3/4" above the bed floor to ensure no interference with the tailgate.

Watch this video to determine the incline of your tailgate:
<https://DECKED.com/pages/cargoglide-install>.

NOTE: Our standard plus nut installation kit is now applicable for both steel and aluminum vehicle beds.

There may be installation situations where an obstruction below the vehicle bed surface prevents using a plus nut, requiring the use of long bolts and/or other fasteners that are not included.

WARNING: PRIOR TO DRILLING HOLES FOR PLUSNUT INSTALLATIONS, CONFIRM THAT THERE ARE NO FUEL LINES, WIRES OR OTHER OBSTRUCTIONS UNDER THE VEHICLE THAT MAY BE DAMAGED WHERE YOU WILL BE DRILLING HOLES.

* See special instructions for electric vehicles and vehicles with generators.

STEP 1: POSITION AND CHECK CLEARANCE

1. It is recommended to first cut the flaps of the box top off and lay it in the vehicle bed to prevent scratches to the bed when positioning the DECKED CargoGlide unit/frame. Be sure to remove the box after positioning the unit/frame.
2. Find a friend and place the entire DECKED CargoGlide unit into the bed of the truck or van. Push to the cabside and center the unit between the wheel wells.
3. Close the tailgate to ensure proper clearance.
4. Check to ensure nothing interferes with the location and operation of the DECKED CargoGlide, including clearance of the tailgate and/or doorway edges.

Loads placed on the DECKED CargoGlide may cause deflection, reducing the tailgate clearance. It is necessary that you ensure at least 1" to 2" between the lowest part of the CargoGlide and the highest point on the tailgate.

Optional spacer kits or drop link kits can be purchased to provide the additional clearance if needed.

5. Open the tailgate, disengage the upper deck latch and pull the deck out to the 2nd position until it locks in place. Measure from the cabside bulkhead to the bottom mounting frame. There should be a minimum of 1/2" clearance. Measure side to side from the CargoGlide to the bed wall at both the front and back of the unit to confirm it is properly centered.

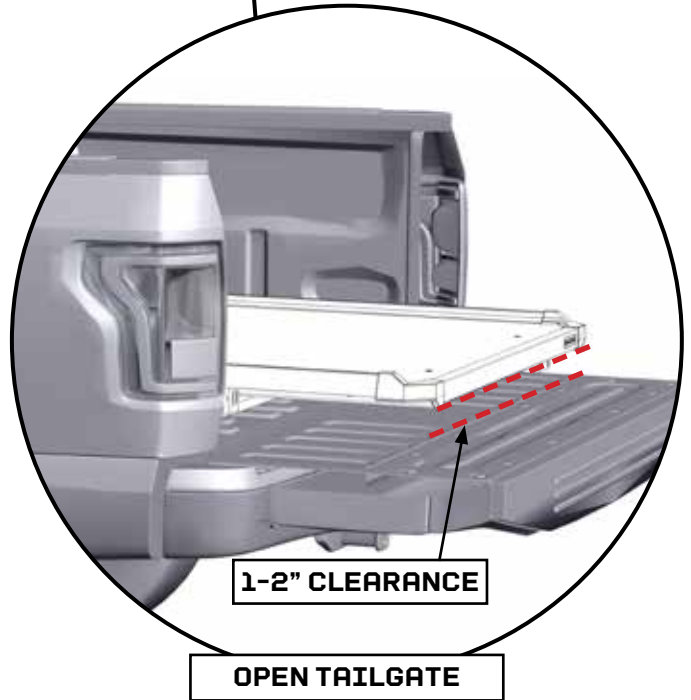
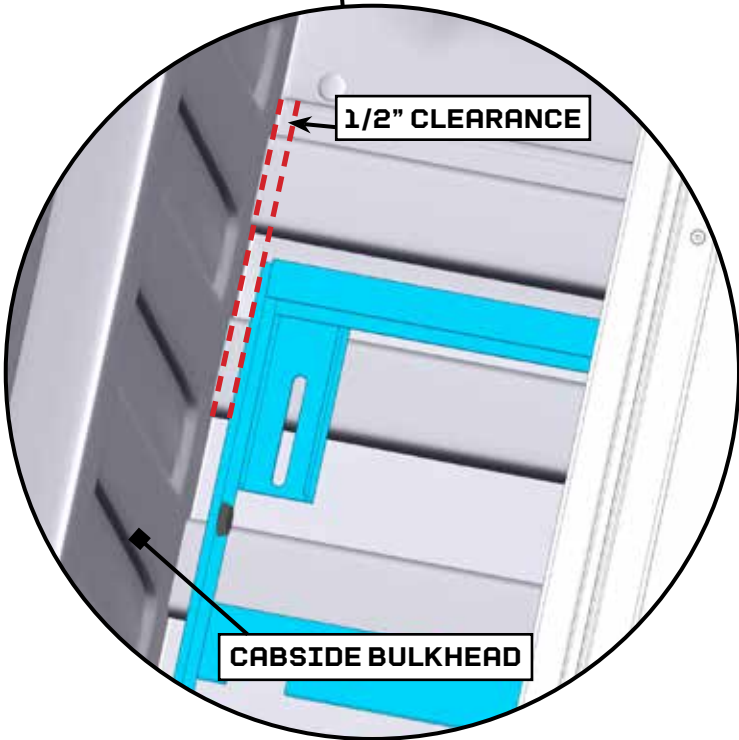
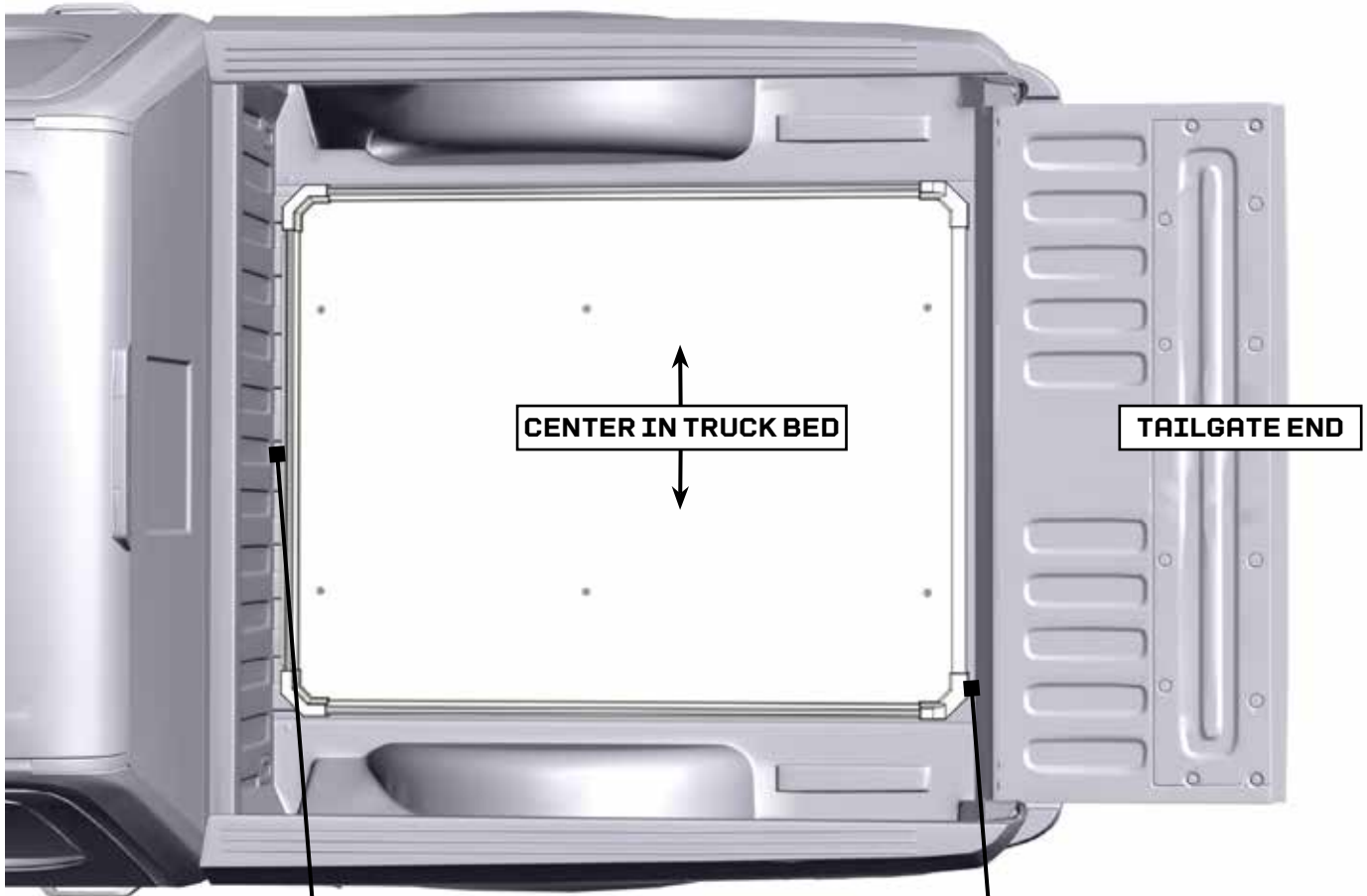

NOTE: ALL ILLUSTRATIONS SHOWN WITH NO HIGH SIDES INSTALLED

STEP 2:

FRAME SEPARATION

1. Verify fitment in the bed with the upper deck installed. Close the tailgate. All good?
2. Remove the upper deck for installation. CG1000XL, CG1500XL and CG2200XL models have hinged stopper flaps on the top and middle frames. To separate frames, simply open the CargoGlide all the way until it stops, then close it a few inches so you can lift the hinged stopper flaps.
3. While holding stoppers flaps up and being careful not to pinch fingers between the stop flaps and the cross bar, hold the latch handle open and slowly slide the deck out until the stopper flaps pass the stop cross bar. Then continue to slide frames apart while holding the frame securely. (Caution: the deck and frames are heavy and will drop abruptly as the last bearing clears the track if not held securely. Two or more people are recommended to carry the frame while it is being removed.)

PULL TRAY OUT UNTIL IT STOPS. CLOSE A FEW INCHES AND LIFT THE STOPPER FLAPS.

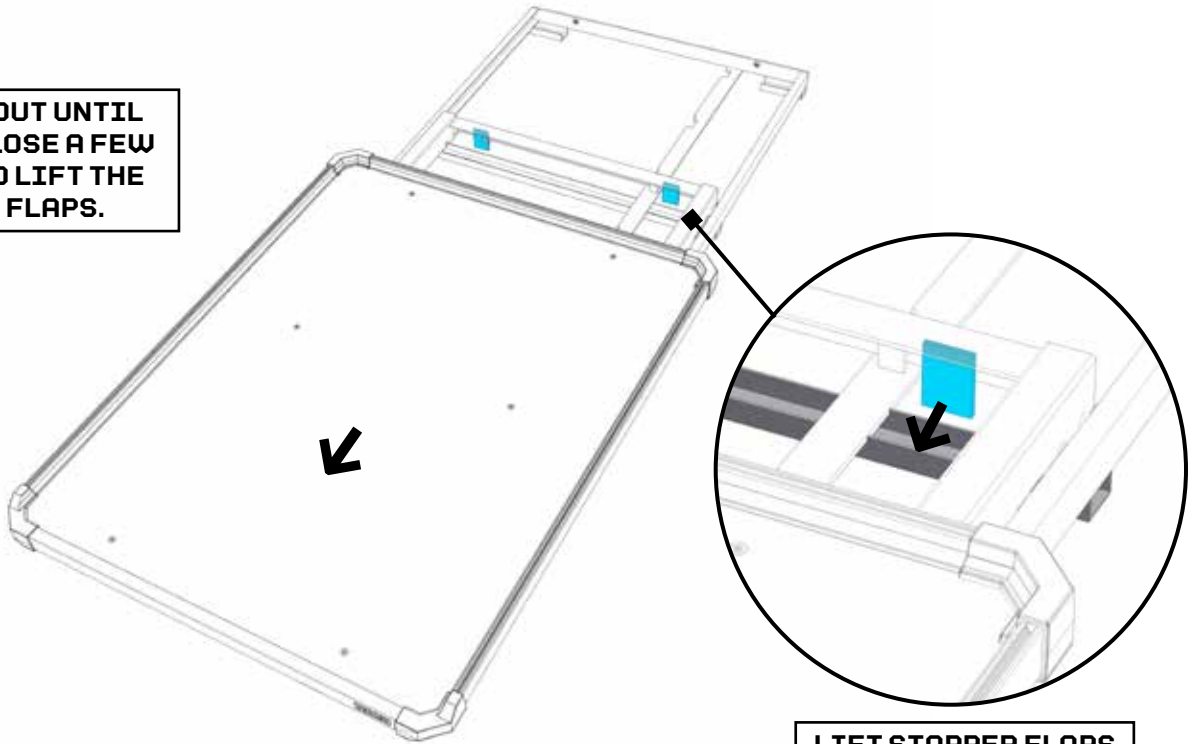

LIFT STOPPER FLAPS

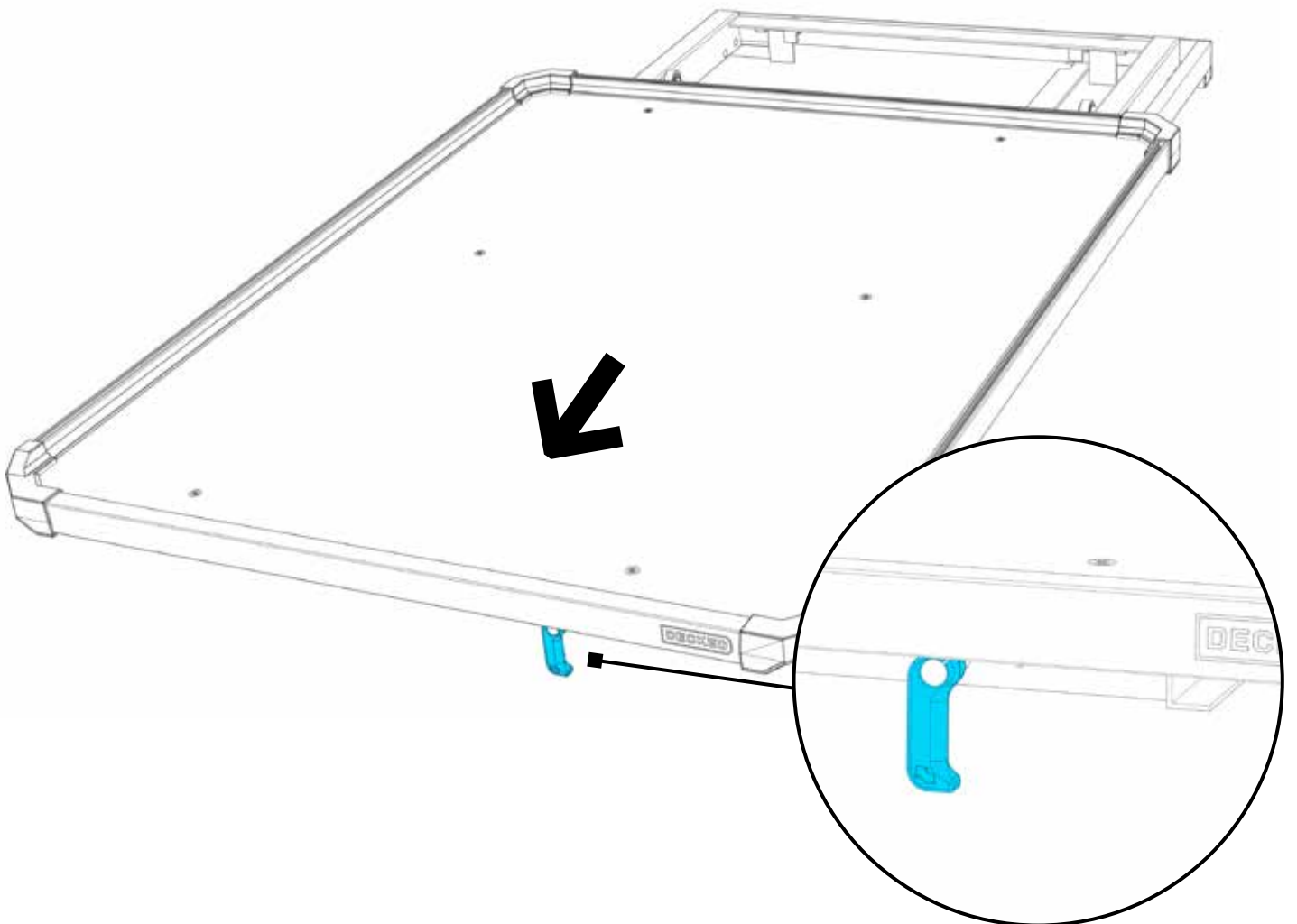

STEP 3:

ALIGN FRAME AND MARK MOUNTING HOLES

1. Plusnut fasteners are provided for easy installation from the top side of most vehicle beds, so you don't have to crawl under your vehicle to bolt in your DECKED CargoGlide.
2. Slots are placed at each fastening point. For most vehicles, these slots ensure plusnuts can be installed on the top and in the middle of the bed ribs.
3. Six (6) mounting points are needed for 52"-56" long CGXL units. (see top right)
4. Six (6) mounting points are needed for 63" - 73" long CGXL units. (see middle right) **NOTE F-150 LIGHTNING/PPO INFORMATION** for proper install into trucks with electrical lines.
5. Eight (8) mounting points are needed for 80" - 95" long XL units. (See below right)
6. Select a fastening position nearest the center on the top of a bed rib in each of the 6 or 8 locations. Mark with a marking pen.
7. Align frame so that all mounting locations reside over the middle of a bed rib. Holes must be placed at least 1/4" from any edges of the top flat rib surface.
8. It is not recommended to install plusnuts in the rib valleys. If this can't be avoided, spacers will be needed to fill the gap.

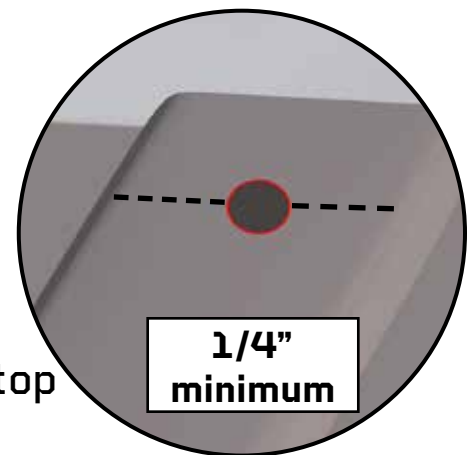

**52" - 56" units
6 mounting holes**

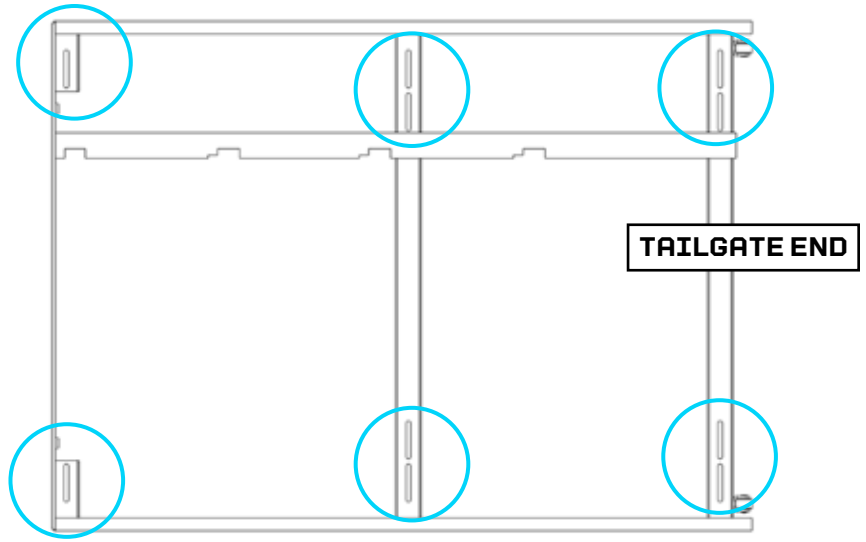

**63" - 73" units
6 mounting holes**

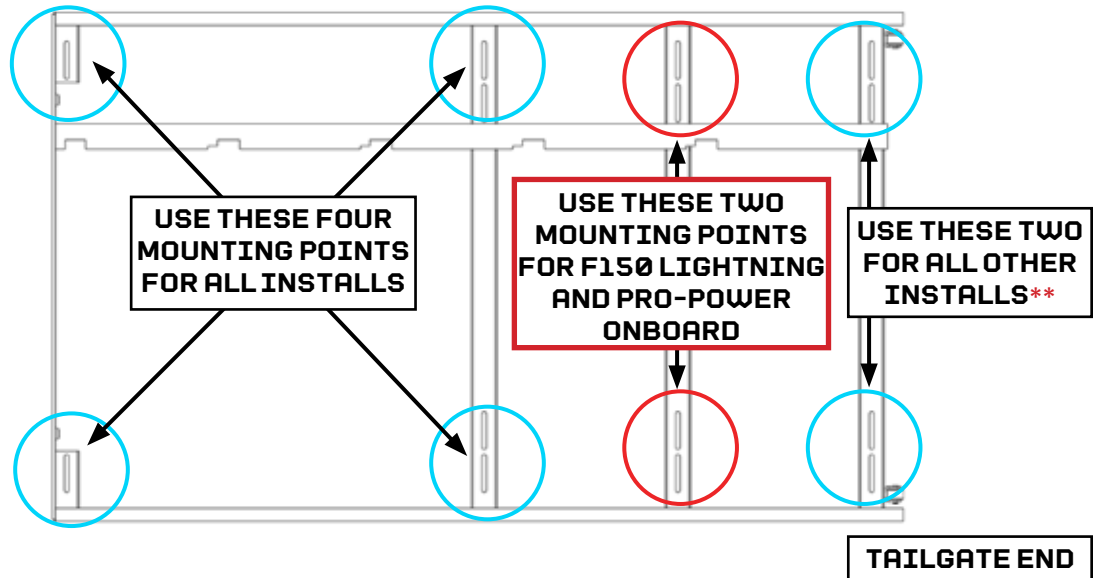

****CAUTION - DO NOT USE TAILGATE SIDE MOUNTING HOLES FOR THE F150 LIGHTNING OR F150'Ss WITH THE PRO-POWER ONBOARD OPTION****

**80" - 95" units
8 mounting holes**

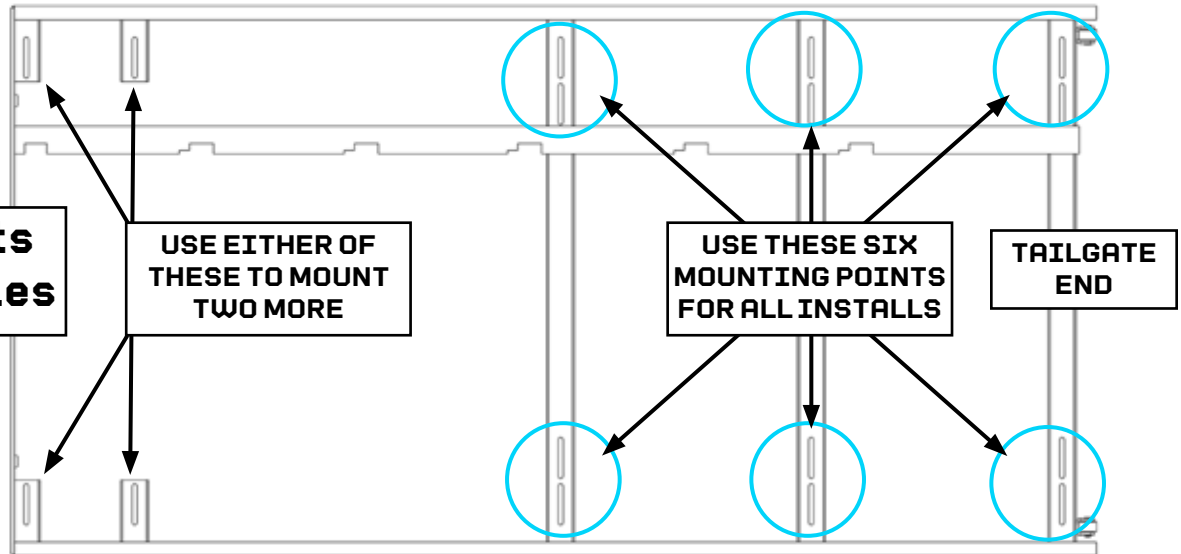

STEP 4:

DRILL MOUNTING HOLES

1. Use the frame as a guide to drill pilot holes in the six or eight mounting locations with the 5/16" bit.
2. A 5/16" installation bolt can be placed in a pilot hole to temporarily secure the unit in place while you drill the other pilot holes.
3. Move the CargoGlide frame a few inches out of your way and use a 1/2" bit to enlarge the holes you just made.
4. Seal the raw edges with the self-etching PRIMER included in your hardware kit. Let it dry.
5. Insert a plusnut anchor into each hole.
6. Using a wrench to hold the plus nut compression tool in place, use a ratchet and socket or impact driver to tighten the bolt into the plus nut. As you tighten the bolt, you will feel strong resistance, then light resistance, then strong resistance again as it crimps the plus nut anchor under the vehicle bed. **DO NOT OVERTIGHTEN.**
7. After the plus nut has been fully crimped, remove the bolt and repeat on the other mounting locations.

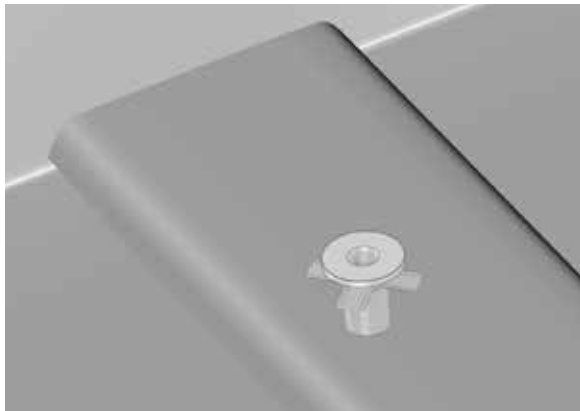
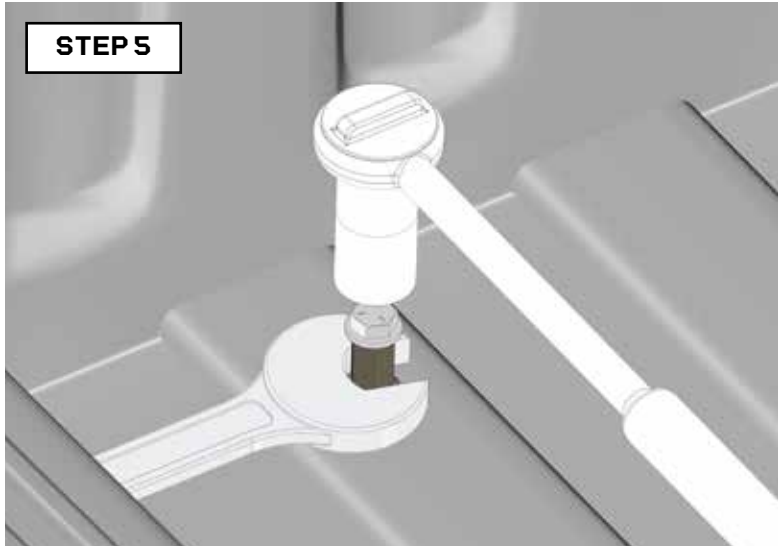
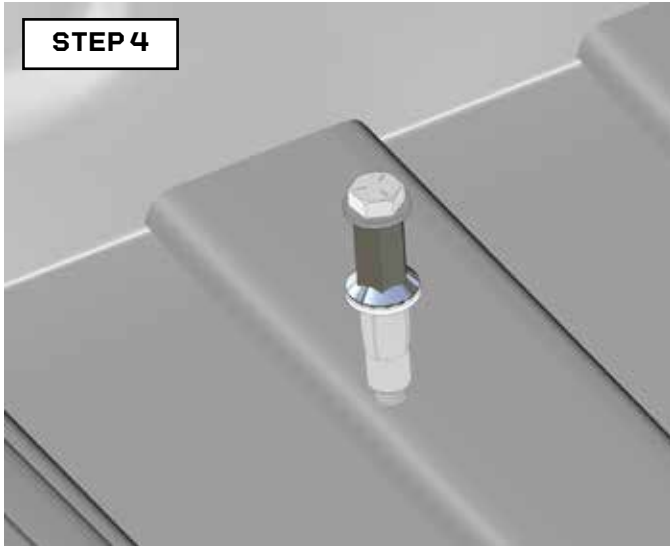
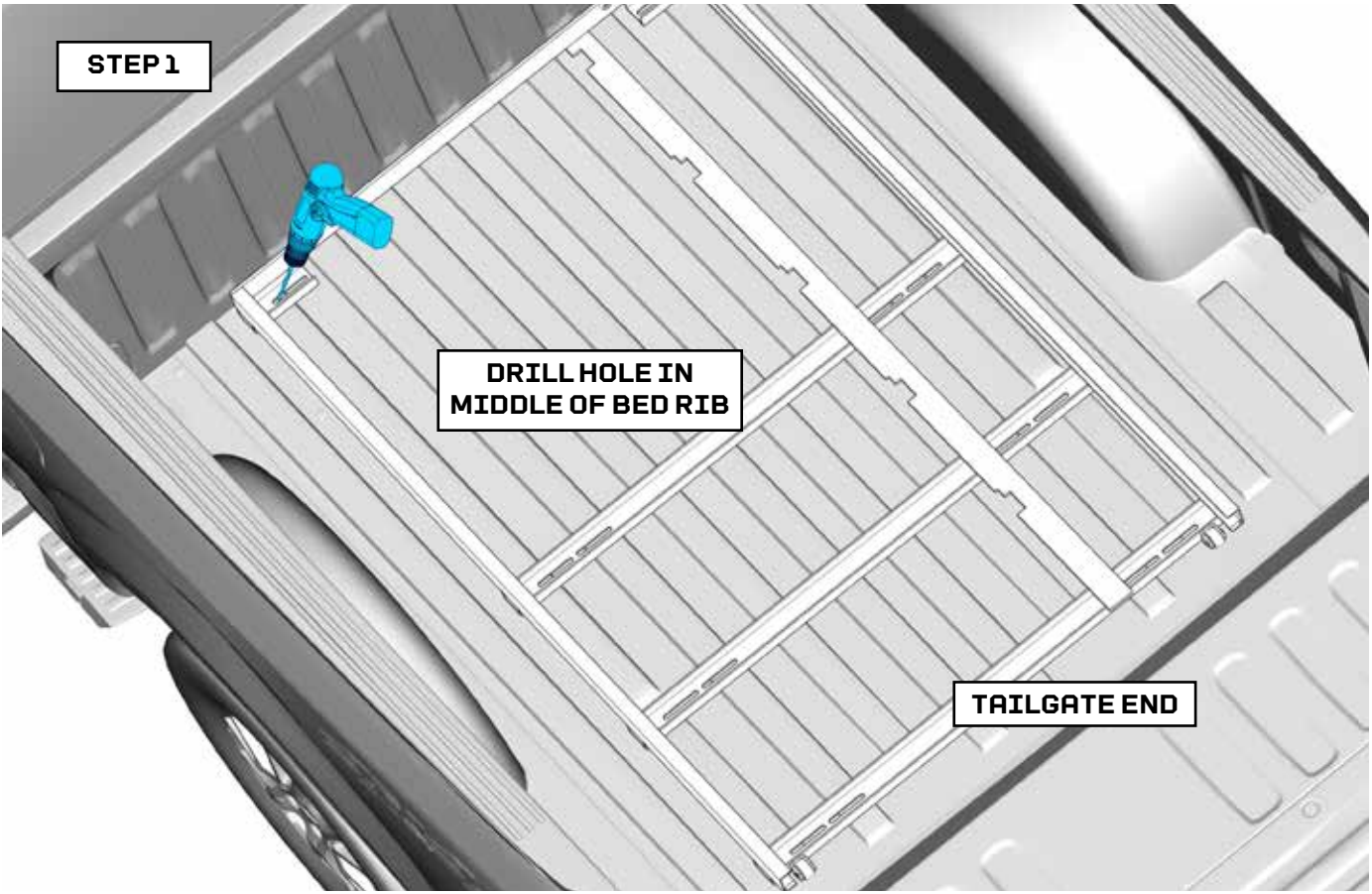

STEP 5: FASTEN AND TEST UNIT

1. Move the frame back into place over the plus nuts.
2. Install the 5/16" bolts from your installation kit. Install a washer on the bolt and install through the mounting hole in the DECKED Cargo Glide frame and into the plus nut. Tighten securely in each of the mounting positions.
3. Reinstall the top frame and tray by simply sliding the frames back into place. The hinged stoppers automatically engage as they pass the stopping points. Make sure the stops have swung into the fully down position, so the CargoGlide frames will not separate unless you manually lift the hinged stoppers.
4. Verify fitment in the bed with the upper deck installed.
5. Inspect periodically to ensure bolts remain securely fastened.
6. SAFETY CHECK: Prior to placing any cargo on the unit, test function: Carefully slide out unit, releasing latch handle to ensure it stops at each stop position and that there is safe clearance for fingers, tailgates, etc.

**CONGRATS,
GAME CHANGER!**

YOU DID IT.

Crack open a cold one of your liking, sit back and admire your work. Now get busy organizin'!

**INSTALL BOLT AND WASHER
INTO EACH PLUS NUT**

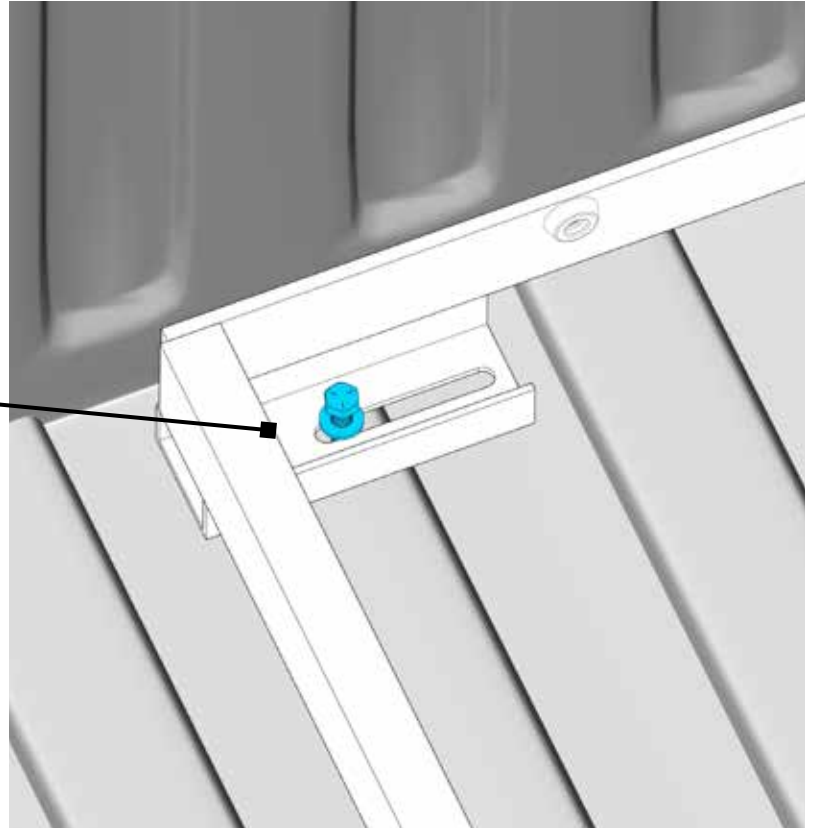
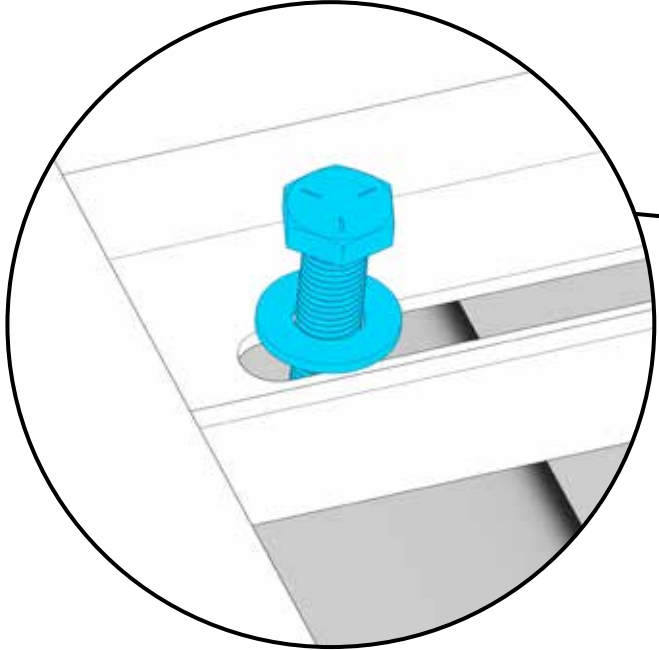

TEST FUNCTION





DECKED PRODUCTS LIMITED LIFETIME WARRANTY

(Valid on DECKED Products purchased on or after 8/1/2021)

DECKED LLC, (the "Manufacturer") warrants the original purchaser only that DECKED Truck and Van Products (The "DECKED" Product) will be free from defects in material and workmanship from the date of purchase and continuing for the expected lifetime of the DECKED Product. The DECKED Product must be registered by the original purchaser with DECKED, LLC via its website at, decked.com/register, and a copy of the original sales receipt must be supplied to the Manufacturer at the time a warranty claim is made. This warranty terminates if the original purchaser transfers the DECKED Product to any other person or vehicle.

WHAT IS COVERED

All DECKED Products identified above on or after August 1, 2021. **DECKED's Limited Lifetime Warranty applies to US and Canadian customers only. International shipments are covered by DECKED's 3 Year Limited Warranty.**

WHAT WE WILL DO TO CORRECT PROBLEMS

Subject to the limitations and exclusions described in this limited warranty, the Manufacturer will remedy defects in workmanship or materials by providing one of the following remedies at its option and without charge to the original purchaser for parts: (a) repairing the defective portion of the DECKED Product or (b) replacing the entire DECKED Product. In addition, the Manufacturer may elect at its option not to repair or replace the DECKED Product, but rather issue to the original purchaser a refund equal to the purchase price paid for the DECKED Product or a credit to be used towards the purchase of a new DECKED Product.

WHAT IS NOT COVERED

This limited warranty expressly excludes:

- Damage or defects caused by normal wear and tear, cosmetic rust, scratches, accidents, unlawful vehicle operation, installation in a non-supported vehicle or installed in a vehicle which does not match the DECKED Product's SKU-intended fitment or use, or modification of the product, or any types of repair of a DECKED Product other than those authorized or provided by the Manufacturer.
- Damage or defects resulting from conditions beyond the Manufacturer's control and specifications including, but not limited to modification, misuse, overloading, or failure to assemble, install or use the DECKED Product in accordance with the Manufacturer's written instructions or guidelines included with the DECKED Product or separately made available to the original purchaser.
- Damage to the contents of the DECKED Product or vehicle.
- TO THE EXTENT PERMITTED BY LAW, IN NO EVENT SHALL THE MANUFACTURER BE LIABLE FOR ANY INCIDENTAL, SPECIAL, INDIRECT, OR CONSEQUENTIAL DAMAGES, INCLUDING ECONOMIC LOSS, WHETHER RESULTING FROM NONPERFORMANCE, USE, MISUSE, OR INABILITY TO USE THE DECKED PRODUCT OR THE MANUFACTURER'S NEGLIGENCE.

NO OTHER EXPRESS WARRANTY APPLIES

This Limited Lifetime Warranty is the sole and exclusive warranty for DECKED Products. No employee, agent, dealer, or other person is authorized to alter this warranty or make any other warranty on behalf of DECKED LLC.

NOTIFICATION PROCEDURES

If the DECKED Product does not conform with the terms of this limited warranty, the original purchaser must promptly notify the Manufacturer in writing upon discovery of the nonconformity. In order to receive remedies under this limited warranty, a warranty claim must have been registered with DECKED LLC by the original purchaser, must describe the nature of the products nonconformity, include a copy of the original sales receipt, invoice, or other proof of purchase and be accompanied with photos or video. Repairs or modifications made to the DECKED Product by other than the Manufacturer or its authorized agent will nullify this limited warranty. Coverage under this limited warranty is conditioned at all times upon the owner's compliance with these required registration, notification, and repair procedures.

Product registration may be performed at:
decked.com/register

Warranty claims must include reciprocal contact information and may be made via certified mail or email to:

DECKED Warranty and Claims
PO Box 885
Ketchum, ID 83340
warranty@decked.com
208-806-0251

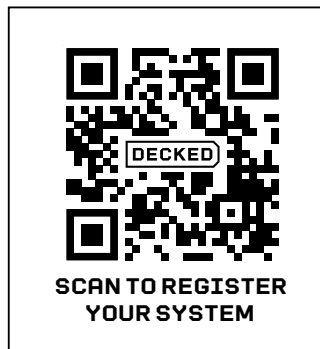

Register your system at
decked.com/warranty

PATENTS

MIDSIZE DRAWER SYSTEM:

US10988087B2, 112017005448.6, AU2017348386A1, 3042037

FULL SIZE DRAWER SYSTEM:

US9527454-B2, USD719905 S, US9168874 B2, CA2969118A1

TOOL BOX:

US20210062581A1

For more information on our patents visit: decked.com/patents